

GENERAL FEATURES

- Rack size **40x40 cm**
- Gross weight: 44 Kg
- Washing cycles / racks/hour: 90"-120"-180"-9"/40-30-20-7
- Top and bottom wash/rinse arm
- Wash pump: 330 W
- Boiler capacity: 3 liters
- Tank capacity: 12 liters
- Boiler heating element: 2,7 kW
- Tank heating element: 2,4 kW
- Water quantity per cycle: 2 liters
- Electronic controls with LCD display
- Useful washing height: 290 mm
- Magnetic door microswitch
- Automatic water filling
- Double electric detergent and rinse dispenser
- Hot rinse
- Thermostop function
- Anti back-flow valve
- Green function for energy saving
- Automatic end-of-day self cleaning of water tank
- Washing pump with Soft-Start

FILTRATION

- Plastic wash pump filter, easily removable

BODY

- AISI 304 stainless steel Body
- Partial double skinned body
- Preformed wash tank
- Preformed rack guides
- Double skinned door
- Door handle in s/s
- Wash/rinse arms in s/s, easily removable
- Boiler in s/s AISI 304
- PVC protection rear the bottom front panel

EQUIPMENT AS GLASSWASHER

- 2 glass racks 40x40 cm
- 1 cutlery small basket
- 1 insert for saucers
- 1 inlet hose (length 2 m)
- 1 drain hose (length 2,5 m)

OPTIONAL

- Drain pump
- Cold rinse
- Hot water filling
- 380-415V3N~50 Hz version
- 60 Hz version
- Kit booster pump
- Kit 4 high feet
- Kit surface filters

ACCESSORIES FOR THE WATER TREATMENT

- Internal water softener ("S" version)

ACCESSORIES

- Special racks (Round, diam. cm 40)
- S/S Supporting stand h. 550 mm. for basket

INSTALLATION

- Use the screws of the feet and a spirit level to ensure that the machine is levelled

MAIN POWER SUPPLY

- The voltage of main power supply must be compatible with the rated voltage
- The machine must be connected to a suitable earth (ground) system
- Connect the machine power socket to the multipole wall switch provide

WATER SUPPLY CONNECTION

- A water softener must be installed if the water is hard
- The water pressure must be between 0.2MPa (2 bar), and, 0.5MPa (5 bar)
- The temperature of the water-supply must be between 10°C to 50°C

TECHNICAL SPECIFICATIONS

- Voltage: **220-240 V / 380-415 V3N~ 50 Hz**
- Total power: **3,03 kW**
- Amperage: **13 A / 4 A**
- Power cord supply size: **3x1,5 / 5x1,5 mmq**

FK 40E LS

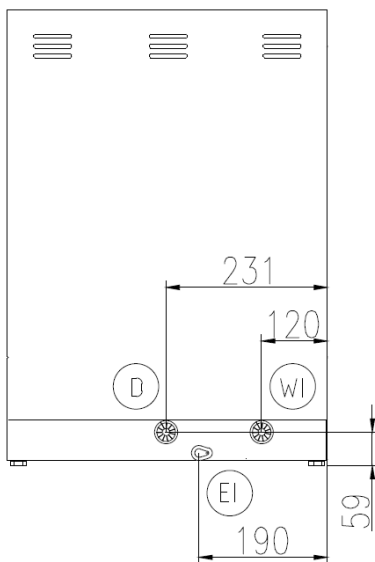
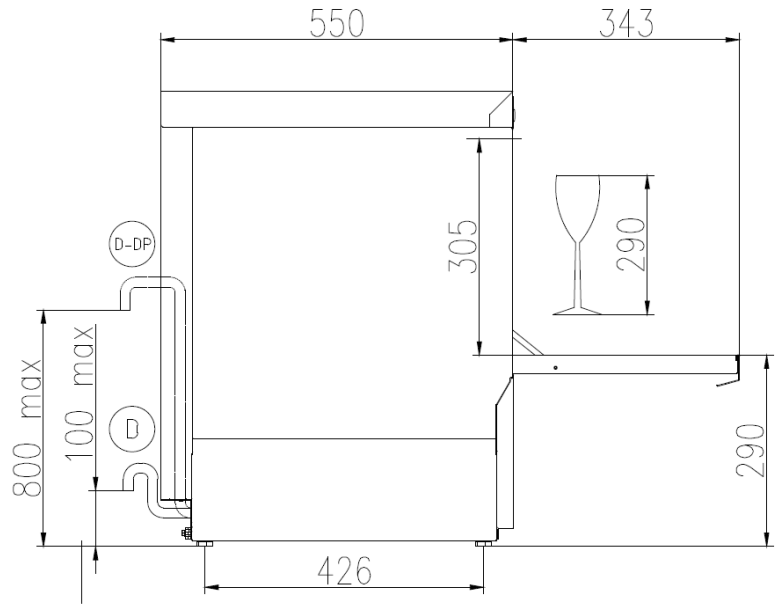
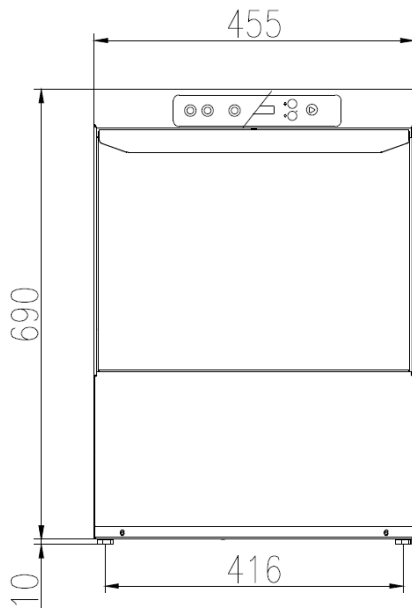

- (EI)** CAVO DI ALIMENTAZIONE
POWER CORD SUPPLY
CABLE D'ALIMENTATION
CABLE DE ALIMENTACION
- (WI)** CANNA DI CARICO G 3/4 L=2000 mm
G 3/4 INLET HOSE L=2000 mm
TUYAU D'ALIMENTATION G 3/4" L=2000 mm
TUBO DE ALIMENTACION G 3/4" L=2000 mm
- (D)** TUBO DI SCARICO Ø 29 mm L=2500 mm
DRAIN HOSE Ø 29 mm L=2500 mm
TUYAU DE VIDANGE Ø 29 mm L=2500 mm
TUBO DE DESAGUE Ø 29 mm L=2500 mm
- (D-DP)** TUBO DI SCARICO Ø 29 mm L=2500 mm (CON POMPA SCARICO)
DRAIN HOSE Ø 29 mm L=2500 mm (WITH DRAIN PUMP)
TUYAU DE VIDANGE Ø 29 mm L=2500 mm (AVEC POMPE DE VIDANGE)
TUBO DE DESAGUE Ø 29 mm L=2500 mm (CON POMPA DE DESAGUE)

	Min 10°C-MAX 50°C
	Min 10°C-MAX 25°C with ENERGY RECOVERY
	200÷500kPa(2÷5 Bar)
	100÷500kPa(1÷5 Bar) with ATMOSPHERIC BOILER
	HARDNESS 5÷20f-2.8÷11°d