

#### GENERAL FEATURES

- Rack size **35x35 cm**
- Gross weight: 39 Kg
- Washing cycles/racks/hour:  
90"-120"-180"-9'/40-30-20-7
- Bottom wash/rinse arm
- Top rinse arm
- Wash pump: 190 W
- Boiler capacity: 3 liters
- Tank capacity: 10 liters
- Boiler heating element: 2,7 Kw
- Tank heating element: 2,4 Kw
- Water quantity per cycle: 2 liters
- Electronic controls with display LCD
- Useful washing height: 250 mm
- Magnetic door microswitch
- Automatic water filling
- Double electric detergent and rinse dispenser
- Hot rinse
- Thermostop Function
- Valvola antiriflusso di serie
- Green Functom for energy saving
- Washing pump with Soft-start
- Automatic end-of-day self cleaning of wash tank

#### FILTRATION

- Plastic wash pump filter, easily removable

#### BODY

- AISI 304 stainless steel Body
- Single skinned body
- Preformed wash tank
- Double skinned door
- Door handle in s/s
- Wash/rinse arms in s/s, easily removable
- Boiler in s/s AISI 304
- PVC protection rear the bottom front panel

#### EQUIPMENT AS GLASSWASHER

- 2 glass racks 35x35 cm
- 1 cutlery small basket
- 1 insert for saucers
- 1 inlet hose (lenght 2 mt)
- 1 drain hose (lenght 2,5 mt)

#### OPTIONAL

- Drain pump
- Cold rinse
- 60 Hz version
- Hot water filling
- Kit 4 high feet

#### ACCESSORIES FOR THE WATER TREATMENT

- Internal water softener ("S" version)

#### ACCESSORIES

- Special racks (Round, diam. cm.35)

#### INSTALLATION

- Use the screws of the feet and a spirit level to ensure that the machine is levelled

#### MAIN POWER SUPPLY

- The voltage of main power supply must be compatible with the rated voltage
- The machine must be connected to a suitable earth (ground) system
- Connect the machine power socket to the multi-pole wall switch provided

#### WATER SUPPLY CONNECTION

- A water softener must be installed if the water is hard
- The water pressure must be between 0.2MPa (2 bar), and, 0.5MPa (5 bar)
- The temperature of the water-supply must be between 10°C to 50°C

#### TECHNICAL SPECIFICATIONS

- Voltage: **220-240 V~50Hz**
- Total power: **2,89 kW**
- Amperage: **13 A**
- Power cord supply size:**3x1.5 mmq**

## FK 35E

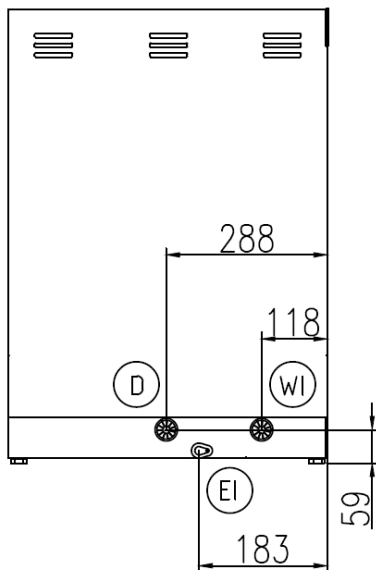
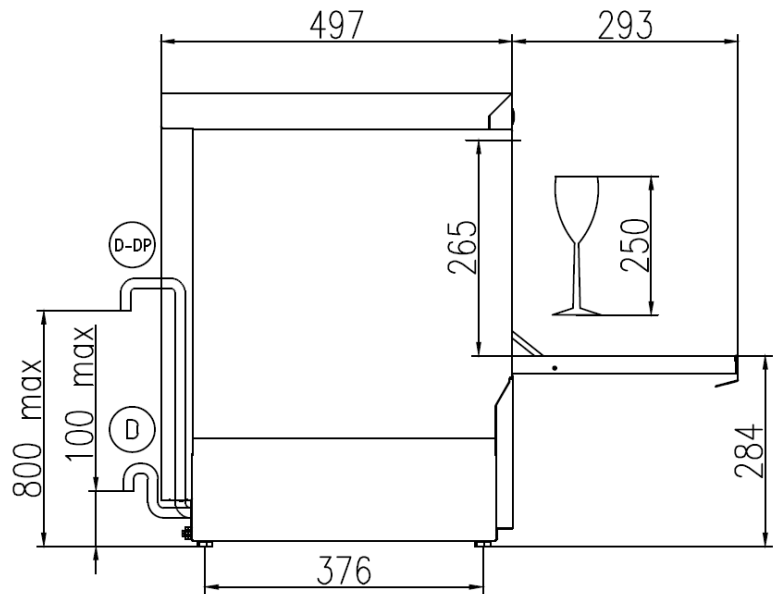
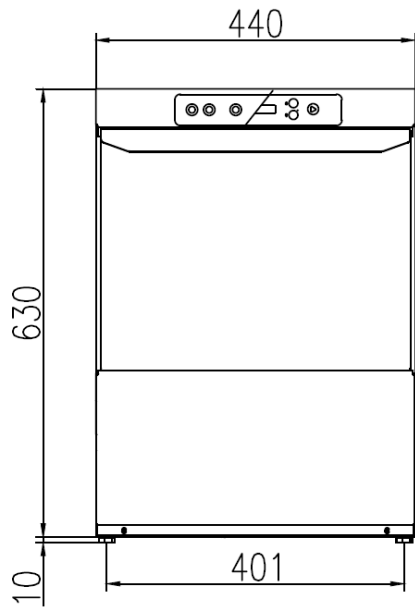

CAVO DI ALIMENTAZIONE  
POWER CORD SUPPLY  
CABLE D'ALIMENTATION  
CABLE DE ALIMENTACION



CANNA DI CARICO G 3/4 L=2000 mm  
G 3/4 INLET HOSE L=2000 mm  
TUYAU D'ALIMENTATION G 3/4" L=2000 mm  
TUBO DE ALIMENTACION G 3/4" L=2000 mm



TUBO DI SCARICO Ø 29 mm L=2500 mm  
DRAIN HOSE Ø 29 mm L=2500 mm  
TUYAU DE VIDANGE Ø 29 mm L=2500 mm  
TUBO DE DESAGUE Ø 29 mm L=2500 mm



TUBO DI SCARICO Ø 29 mm L=2500 mm (CON POMPA SCARICO)  
DRAIN HOSE Ø 29 mm L=2500 mm (WITH DRAIN PUMP)  
TUYAU DE VIDANGE Ø 29 mm L=2500 mm (AVEC POMPE DE VIDANGE)  
TUBO DE DESAGUE Ø 29 mm L=2500 mm (CON POMPA DE DESAGUE)

	Min 10°C—MAX 50°C
	Min 10°C—MAX 25°C with ENERGY RECOVERY
	200÷500kPa(2÷5 Bar)
	100÷500kPa(1÷5 Bar) with ATMOSPHERIC BOILER
	HARDNESS 5÷20°f—2.8÷11°d